

Troubleshooting

7.1 Overview

This section is very important, if your machine has issues.

7.1.1 Attention

Our machine is an intergration of mechanical components, Digital components, electrical components, personal computer and software.

The following are some events which may cause the machine not work correctly.

- The machine was transported, and wiring may have come loose
- There was a thunderstorm w/ lightning since the machine was last used and now the electronics do not work.
- There has been water in the area where the machine is located
- The machine is in unheated outside building.

7.1.2 Troubleshooting overview

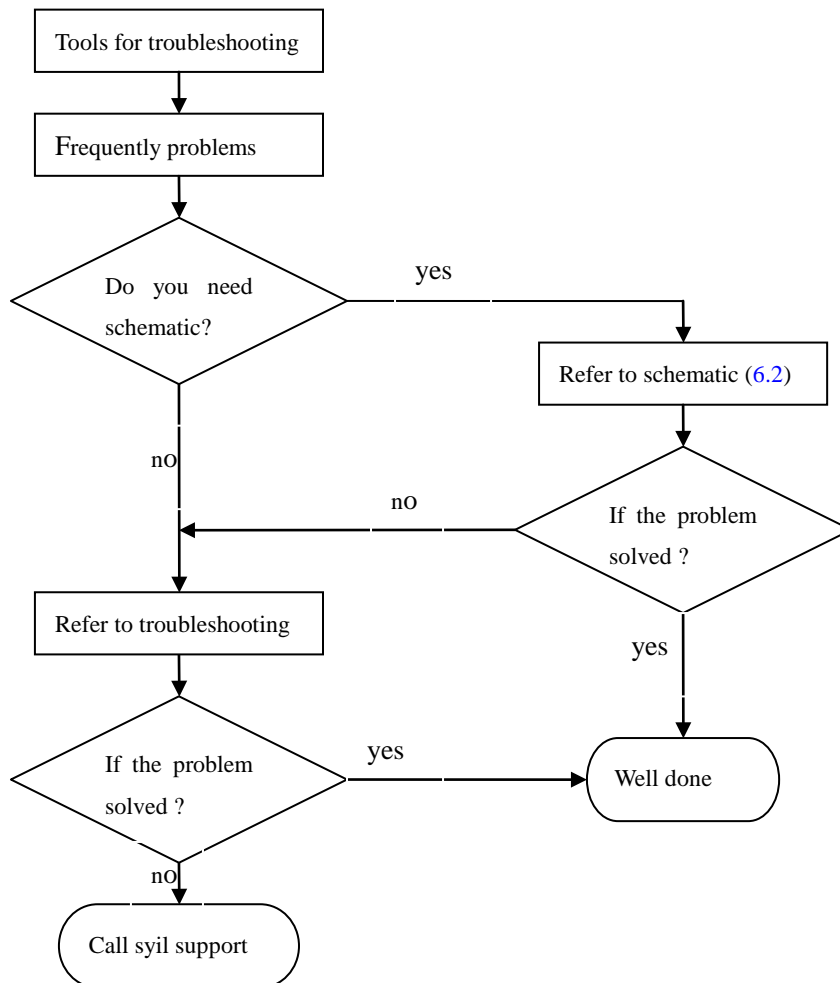

Figure 7-1

This is the troubleshooting overview, as Figure 7-1, you can try to solve the problem as above, the next will instruct the all process detailed.

Attention for troubleshooting:

- Have knowledge of how machine is supposed to work.
- Divide and conquer—focus on one area
- Analyze what has changed
- Work smart—do the easy and obvious tests first
- Complete one test before starting another.

7.1.2.1 Tools for troubleshooting

7.1.2.1.1 Safety

- ***Never do anything with machine power on that can be done with machine power off.***
- **Wear eye protection and use appropriate protective clothing such as gloves**
- **Don't wear loose clothing**
- **Don't wear jewelry as this can contact electrical components.**
- **Do not do any electrical testing if the floor is wet.**
- **Do not plug machine in to receptacle if floor is wet.**
- **Be very cautious on which electrical components you are going to touch, as capacitors can hold a charge even with the machine powered off.**
- **Think about each move you are going to make prior to doing so, and if you are unsure do not proceed.**
- **Focus on the specific task, as working on electrical components can be very dangerous.**

7.1.2.1.2 Tools for troubleshooting

- Good lighting (trouble light or a headlamp or flashlight)
- A digital multi-meter that can test AC volts, DC volts and resistance.
- Assorted non magnetic rubberized screwdrivers.
- A wire stripper
- Measuring tools: Tape measure, Calipers, Dial Indicator(Optional).

7.1.2.1.3 Frequently problems

There are several problems frequently, if your machine has issues, you can try to solve the problem by doing the following.

- *Loose wires:*

There are many wiring connections, it only takes one loose connection to cause the whole machine to fail. Syil has ensured the wiring connections are tight at the factory, but when the machine is shipped to you, the connection may come loose. The first thing to always check is the wiring connections, tighten all harnesses.

- Poor cable connections:

As the same reasons for above, the cable also may become broken or loose, if the machine cannot function normally, please check all cables(include all the cables inside of the control box and the parallel port cable), if you find that a wiring harness is broken contact your local regional dealer or Sales@syil.com.cn

- Software and parallel port problem:

It is best to, restart software or reinstall mach3, the problem may be solved ,if you change any setting in mach3 ,this may also cause a mach3 error.

If mach3 works and the machine works but there is still no communication to the machine, You should check your computers parallel port. It is possible for the personal computer port to be broken ,there is two ways to solved the problem:

- 1.Change the mother board of your computer or change another computer and test again.

- 2.Purchase a PCI-Parallel board and install it on the PCI port of your motherboard. Be aware that the port address will change, you will need to change this address in the (ports and pins) settings in mach3.

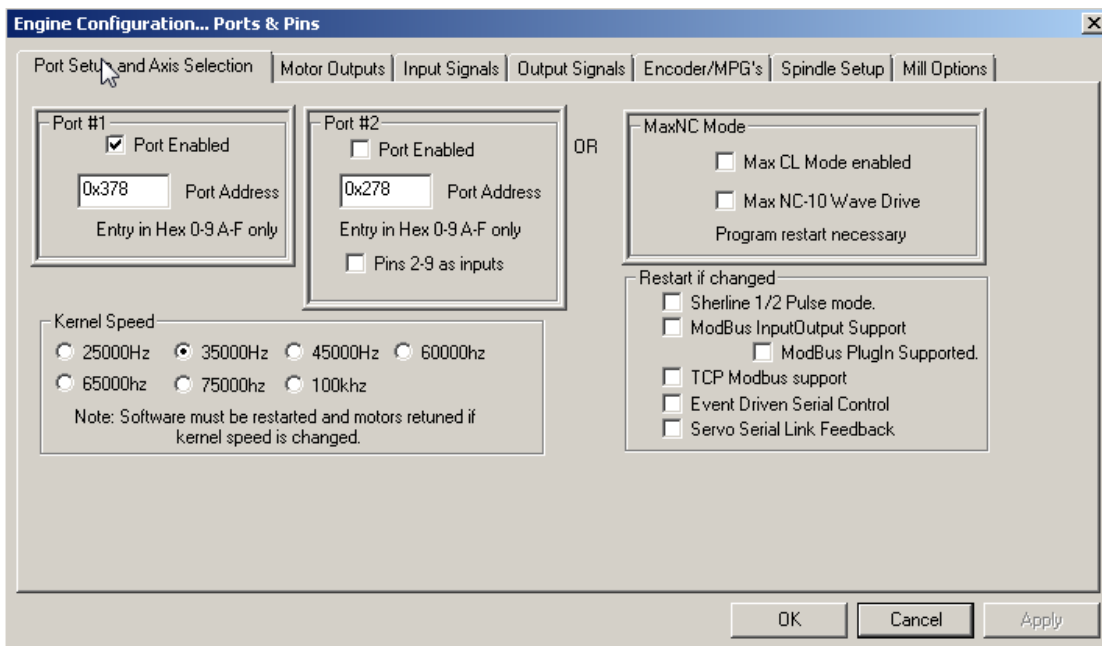

SYIL DOES NOT ADVISE USING A LAPTOP COMPUTER TO RUN MACH3, AS LAPTOP COMPUTERS PARELLEL PORTS CAN HAVE ISSUES WITH KEEPING THE PROPER 5V SIGNAL REQUIRED. You will see the same warning on the mach3 web site.

- Sensors

The homing sensors are install on each axis, these switches are used for homing the machine, if the sensors is broken, the machine will loose the homing

function. To Test go to the diagnostic screen in mach3, depress the switch on the x or y axis. You will see the lights light up.

These are not limit switches and by default will not stop you machine from going past them. Mach3 has a function called (soft limits) this function can be turned on from the main screen for mach3 and set up in the homing/limits settings. This is found under the "Config" menu in mach3. For more reference please check the

mach3 manual, this can be found @
<http://www.machsupport.com/documentation.php>

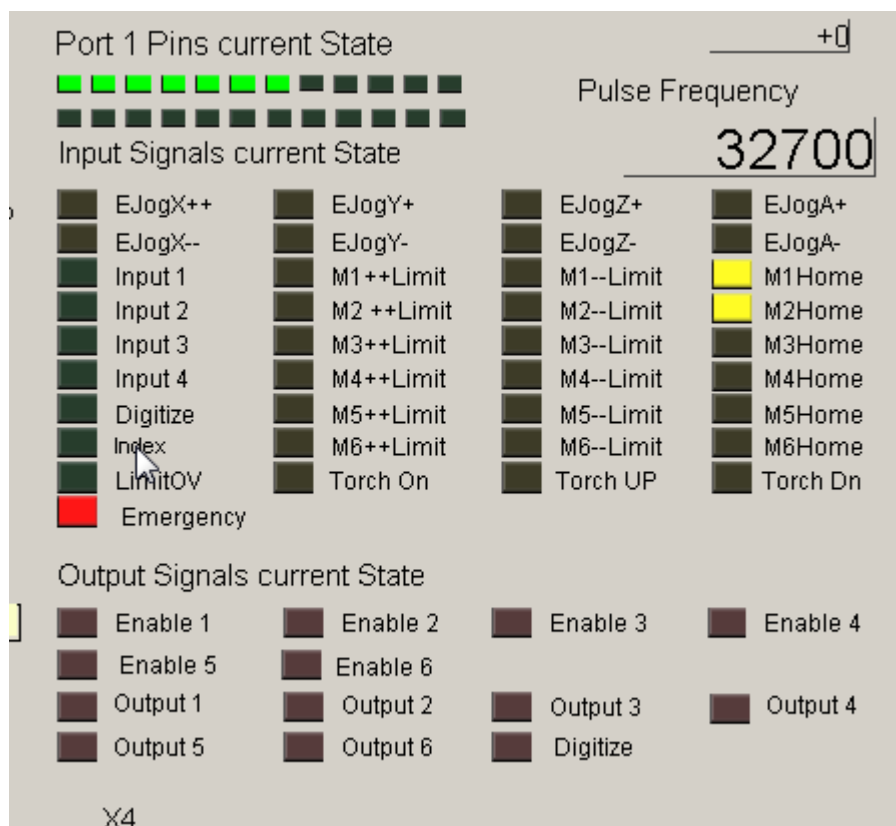

This is also a good way to test the communication to the computer.

- Computer

The recommended configuration of computer: CPU is 1GHZ, EMS memory is 256MB, hard disk space is 150MB,if the computer is old, mach3 may not will run.

- unlicensed software

When you run program in mach3,the program may limited in 999 lines, because yours is demo version, you will need to buy the license, and there will no line limiting.

- Unexplained stop

This may be caused by electrical noise, this can be caused by the homing switch, it is important to use good quality shielded cables.

7.1.2.1.4 Syil support

support@syil.com.cn

sales@syil.com.cn

0086-574-62735995

You can send email for troubleshooting in anytime, or call us in work time, the work time is 8:00-17:00(GMT+08:00), prior to contacting us, be sure you have the following information.

- Serial number of your machine. (Located on the top of column)
- If you have found a problem the machine, and may need to replace some parts from Syil, we will need to know the date of purchase you, the syil Machines carry a [One-year warranty](#). If the warranty has expired you will need to purchase new components.
- Analyze what might have changed since the machine worked properly.
- Make sure you can repeat the problems.
- Describe the problem as detailed as possible, it will help us to diagnose what will need to be fixed.

7.2 Troubleshooting

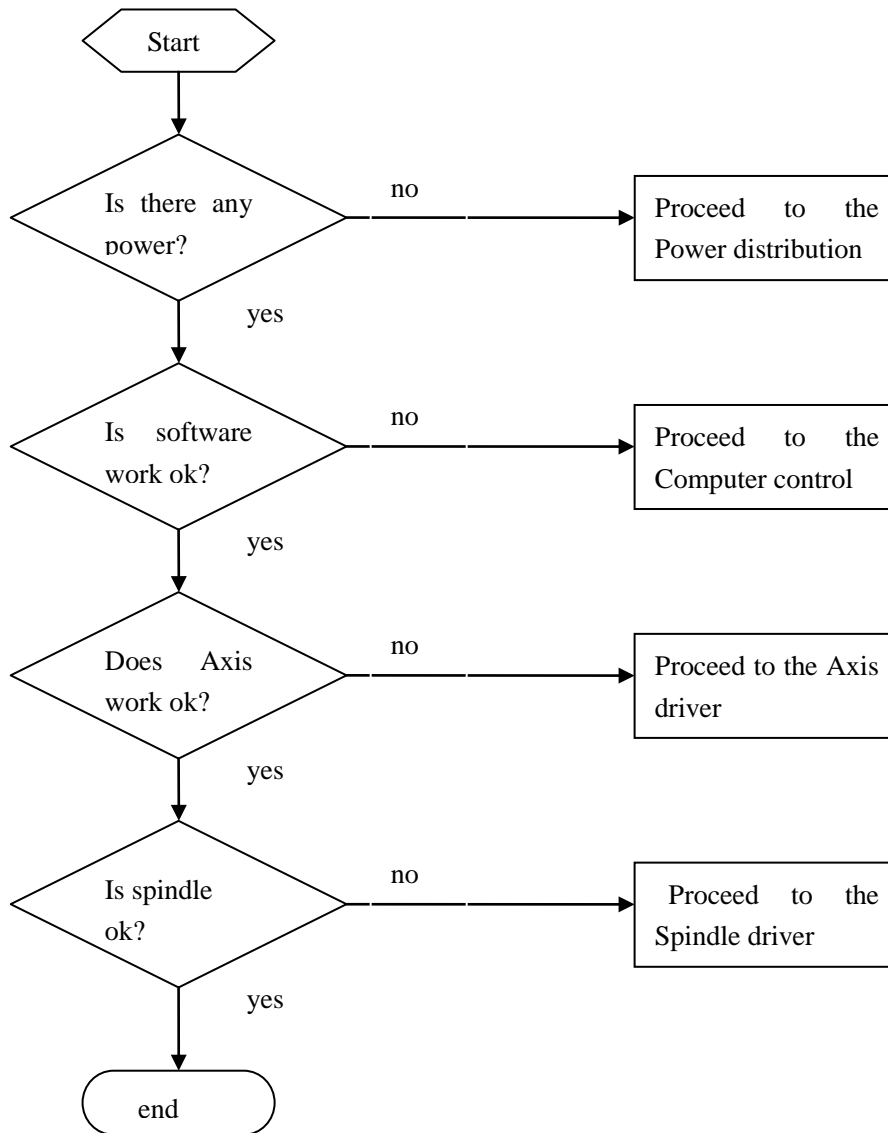

Figure 7-2

The flowchart in figure 9.18 will guide you where to start troubleshooting the electrical system.

This is the power switch, when it switch to "0",the power is disconnect, and when the switch is on "1", the machine will get power supply.(as Figure 7-3)





Most problem of the power supply is caused by the switch.

The following is power distribution check list:



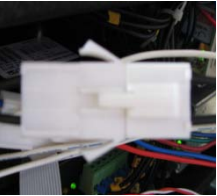

Figure 7-3

7.2.1 Power distribution

parts	Input power	Output power	Remark
Power supply (x4 plus only)	220vac(110vac)	5vdc:supplies power to the x4 plus control board	
Transformer (x4 series)	220vac(110vac)	40vac:Supplies power to the stepper motor driver 24vac:supplies power to the A.C.contactor 12vac:supplies power to the interface board	
Power supply (x4 speed master only)	220vac(110vac)	12vdc:supplies power to the x4 plus control board	

7.2.1.2 Problem resolution checklist for power distribution

Problem	Action to identify cause of problem	How to solve	Remark
•After turning on the power, there is no power in circuit	1. Check the power plug..	1. make sure the connection is good. If the power plug have any problems, replace it immediately.	

	2.Check the switch.	2.if the switch is broken replace the switch. This can be confirmed via volt meter	
• Loose wires in circuit	1.Remove power from machine ,than check ALL connections wires.	1. Find loose wires, and re insert.	
The boards have no power.	1. the spindle control board has no power .	1.Check the fuse or filter, if the board is broken, replace it.	
	2.the five axis board in no power.	2.check the fuse on the board or the power supply to the board, . if the board is broken, replace it.	
Coolant pump is no power supply	1.Check the power plug..	1.if the plug is loose ,tight it.	
	2. Check the second relay.	2.If the relay is not working, replace it.	

7.2.2 Computer control

7.2.2.1 Overview

Mach3 can work well in windows xp.

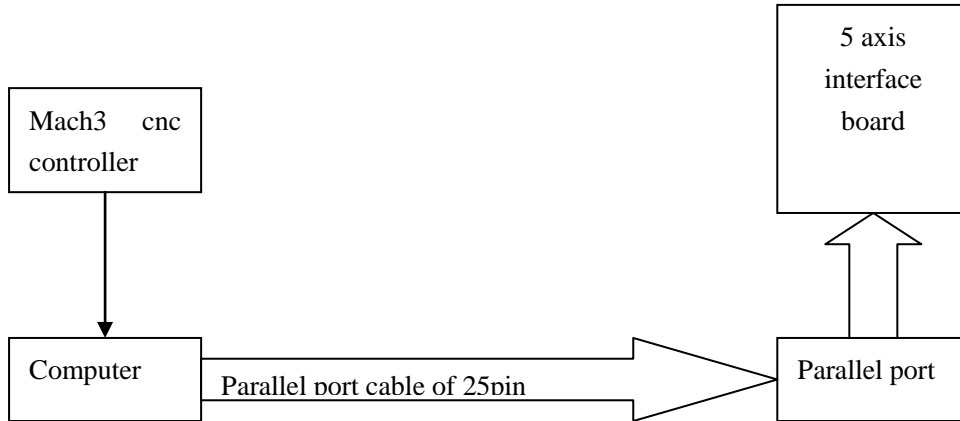





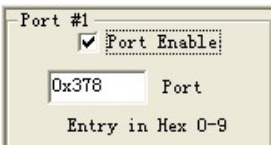

Figure 7-4

7.2.2.2 Problem resolution checklist

Problem	Action to identify cause of problem	How to solve	Remark
The machine can't be controlled by computer	1. check the parallel cable between computer and machine.	1. make sure the connection is good. If the cable has problems, replace it with high quality shielded cable.	
	2. check the parallel port	2. If the parallel port on the machine is broken replace it.	
Mach3 can work, but machine will not work.	1. check the parallel cable	1. Make sure all connections are tight. If the parallel cable appears to have issues, replace it.	

	<p>2. Check that if the mach3 Driver has install properly.</p>	<p>2. Make sure the mach3 driver installed. In the mach3 folder there is a test program ,for the driver</p>	
	<p>3.Make sure that mach3 is working correctly.</p>	<p>3.if suspected that mach3 is not working properly reinstall</p>	
<p>If the machine and the computer is ok, but the machine is still not able to be controled</p>	<p>1.check the power for interface board .</p>	<p>1.if there is no power, check the power supply.(as 6.6.1)</p>	
	<p>2. check the charge pump.</p>	<p>2 make sure the charge pump is working, if the charge pump is not working refer to 6.6.1 as the entire machine will not work</p>	
	<p>3.if you are using a parallel port card, check the address of port1</p>	<p>3.make sure your address is as same as the parallel port card.</p>	

7.2.3 Axis driver

7.2.2.1 Overview

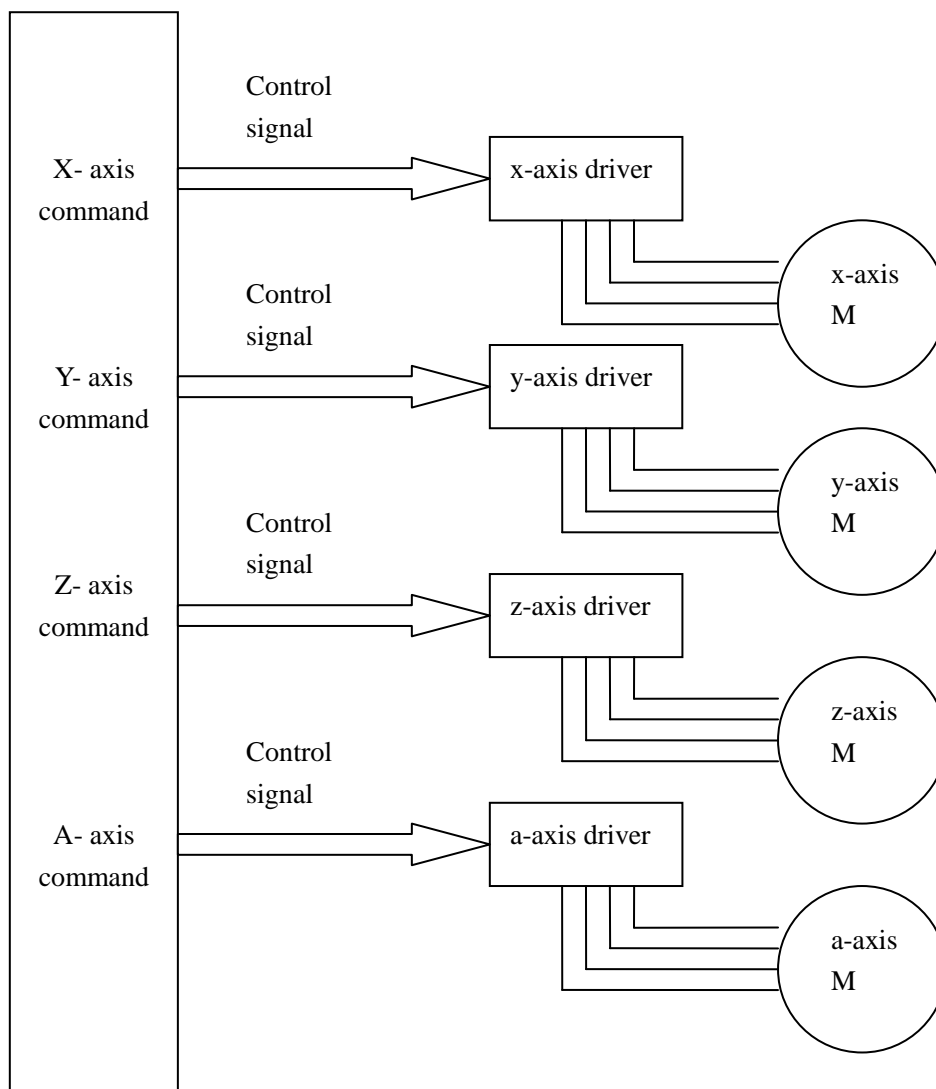









Figure 7-4

7.2.2.2 Problem resolution checklist

Problem	Action to identify cause of problem	How to solve	Remark
A specific axis can't be controlled by computer	1.check the parallel cable between computer and machine.	1. make sure the connection is good. If the cable has issues, replace it.	
	2.check the parallel port	2. if the parallel port is broken replace it.	
	3.check mach3	3.if the software is broken by unknown problem, reinstall it	
stepper motor loses steps when machining.	1. check mach3	1.check mach3, and reinstall.	
	2.check step motor and wiring, For example, x, axis have some problem, you can do as Figure 7-6	2. if stepper motor have having issues, replace it. Do not unplug stepper motor with machine on and computer on. This will cause 5 axis card to not work	
stepper motor driver is not work.	1.check the power supply for driver	1.if the driver is no power, check the wiring.(refer to 6.6.3)	
	2. do as Figure 7-5 to check the cable of control signal.	2 .if the cable is broken, replace it	

<p>The driver and the stepper motor are working, but the axis is not moving.</p>	<p>1. Check the coupling on the motor.</p>	<p>1. if the coupling is broken, replace it.</p>	
<p>axis is limited by limit switch or e-stop switch</p>	<p>1. check the homing switch</p>	<p>1. If the homing switch not working replace it. Refer to <i>7.1.2.1.3 Frequently problems</i></p>	
	<p>2. check the e-stop switch</p>	<p>2. if the e-stop switch is not working replace immediately, do not change settings in mach3 to disable switch!</p>	
<p>Mechanical problem</p>	<p>1. Gibbs are too tight or too loose</p>	<p>1. Adjust Gibb set screws</p>	
	<p>2. oil not getting to the ways</p>	<p>2. investigate oiling system for lack of oil and/or plugged lines</p>	
	<p>3. debris on ballscrew.</p>	<p>3. clean ballscrew</p>	

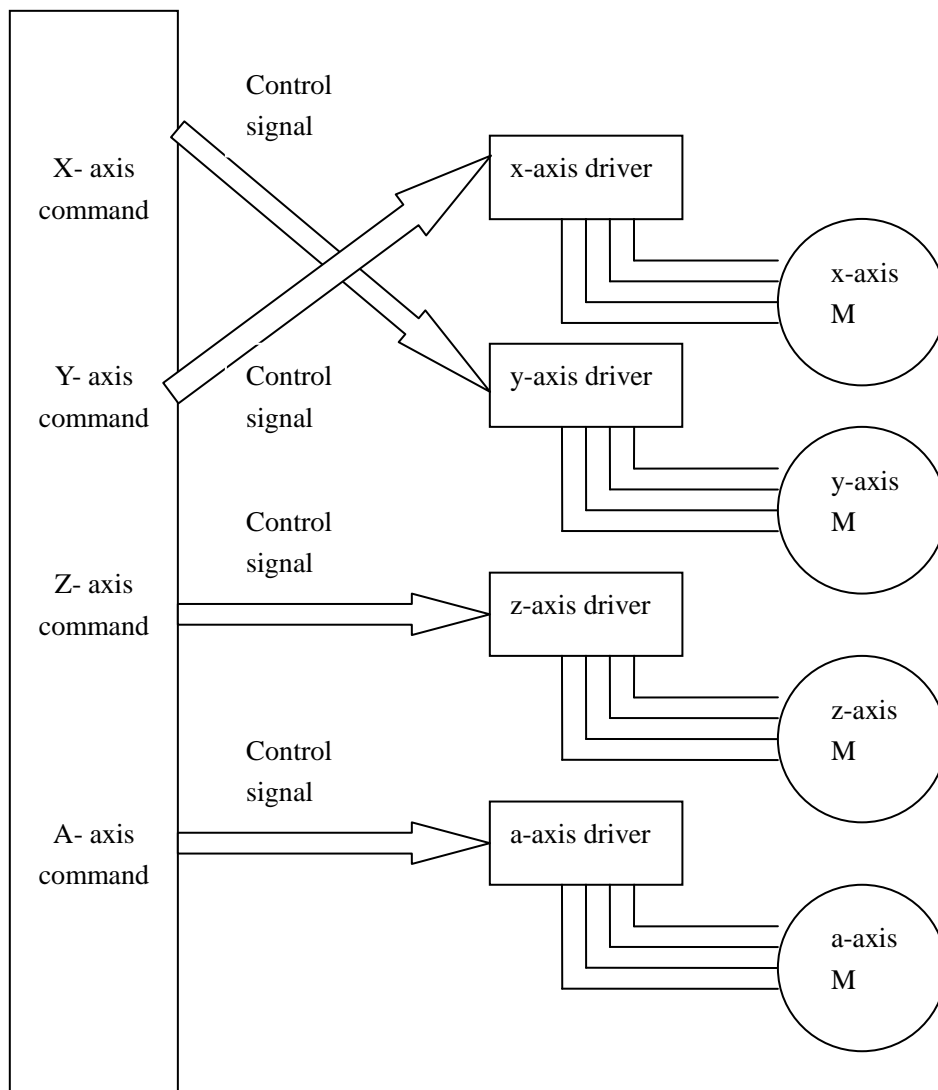

Figure 7-5

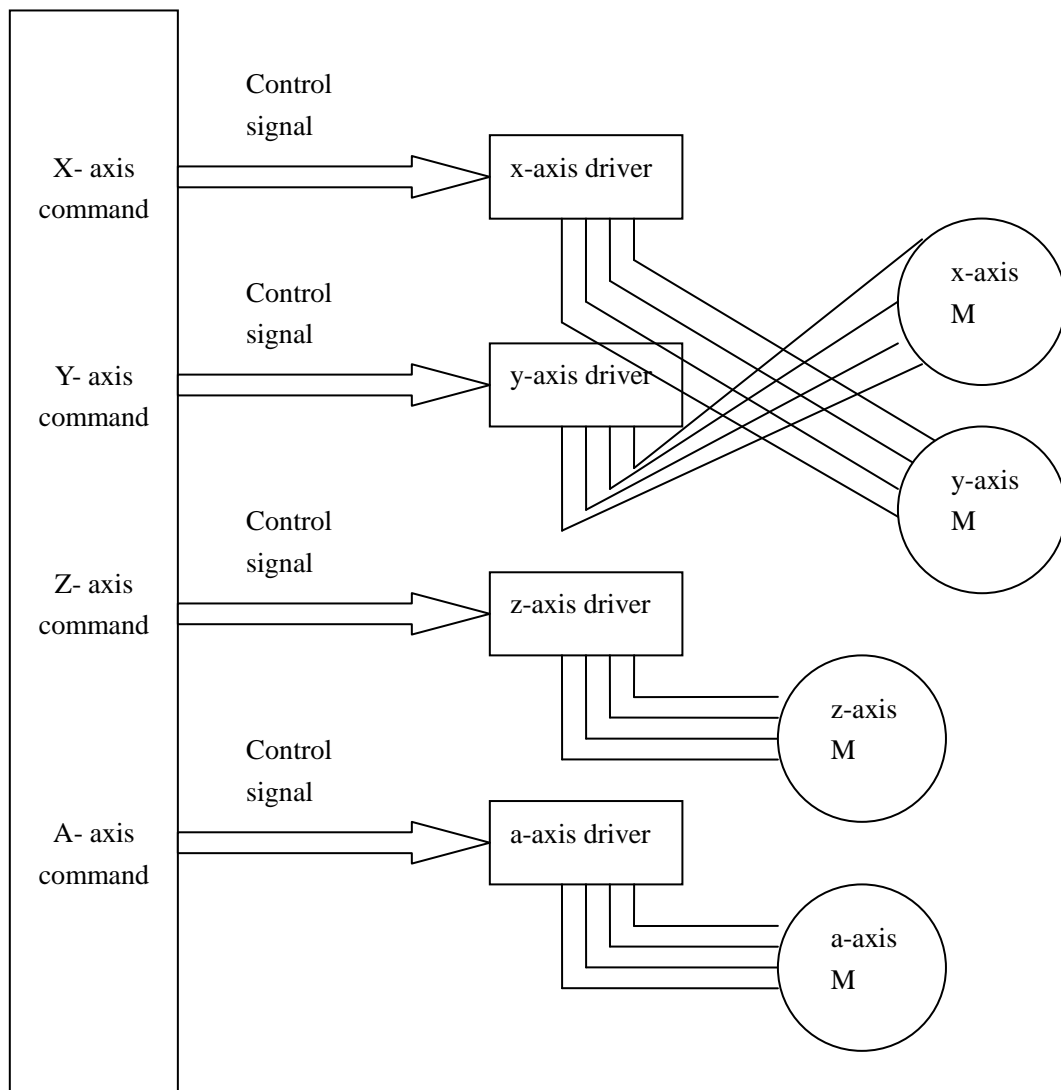

Figure 7-6

7.2.4 Spindle driver

7.2.4.1 Overview for x4

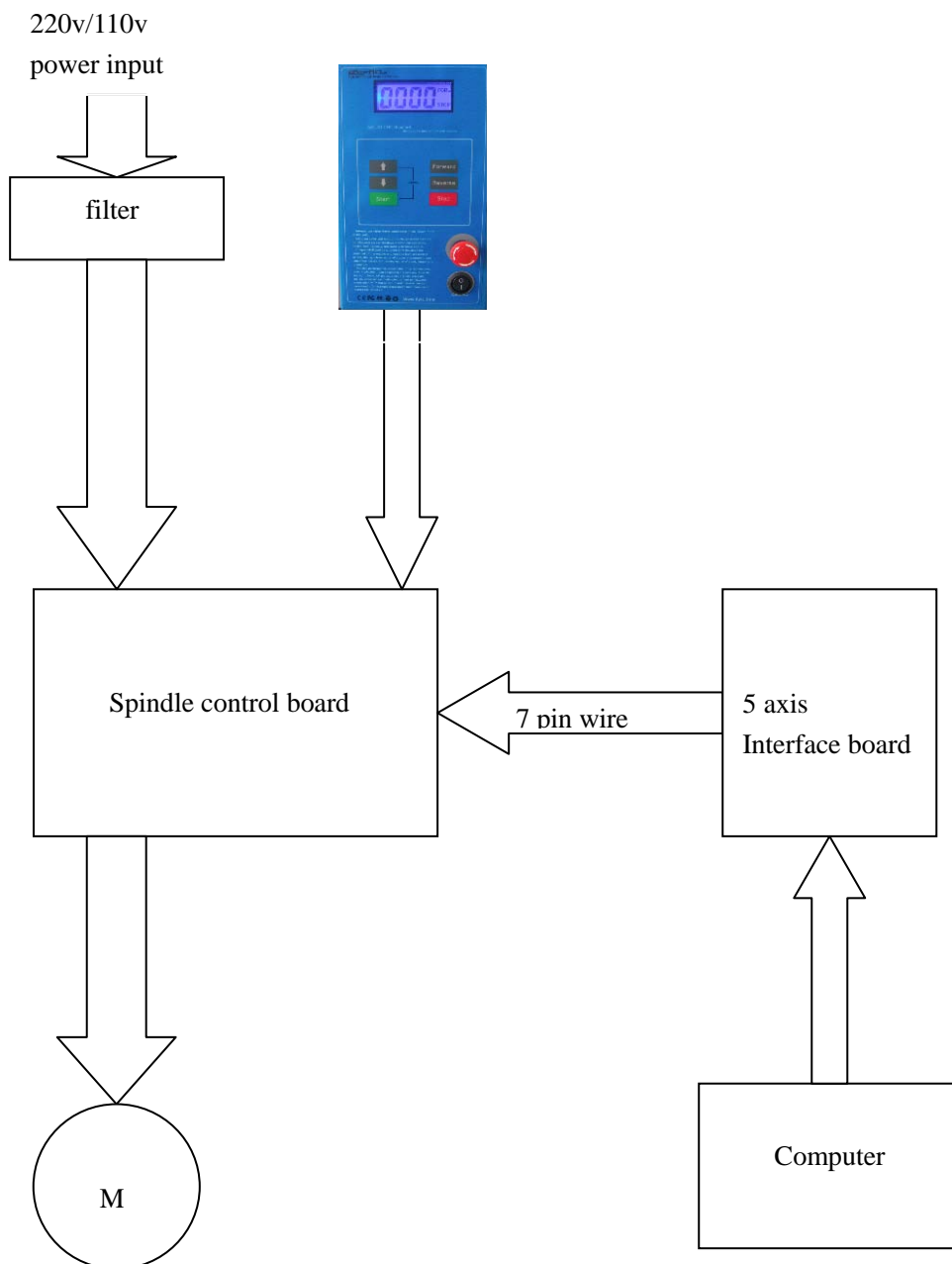







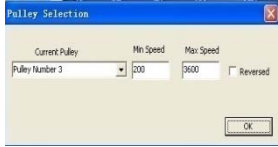
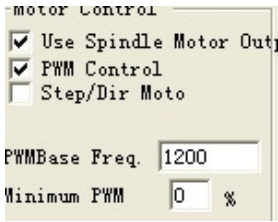

Figure 7-7

7.2.4.2 Problem resolution checklist for x4

Problem	Action to identify cause of problem	How to solve	Remark
The spindle can't be controlled by computer.	1.check the parallel cable between computer and machine.	1. make sure the connection are good. If the cable have suspected problems, replace it.	
	2.check the parallel port	2. if the parallel port is broken replace it.	
	3.check mach3	3.if the software is broken by unknown problem, reinstall it	
	4.check the 7 pin wire	4.if the wire is broken, replace it	
	5.check the 5 pin wire	5.If the wire is broken, replace it	
	6.check the spindle control board	6.if the spindle control board is broken, replace it. To test check that the board is getting power.	
	7.check the spindle motor	7.if the motor is broken ,replace it	

	<p>8.check the spindle switch, if the switch is broken ,the spindle will only be controlled in manual mode.</p>	<p>8.If the switch is broken, replace it.</p>	
<p>The spindle does not achieve programmed RPM. For example, use "m3s1500", but the true RPM is only 1000</p>	<p>1. check set of pulleys in mach3</p>	<p>1.Make sure the pulley is 200 to 3600</p>	
	<p>2.check motor control in mach3</p>	<p>2.Make sure the PWMbase freq. is 1000 to 1500.</p>	

7.2.4.3 Overview for x4 plus

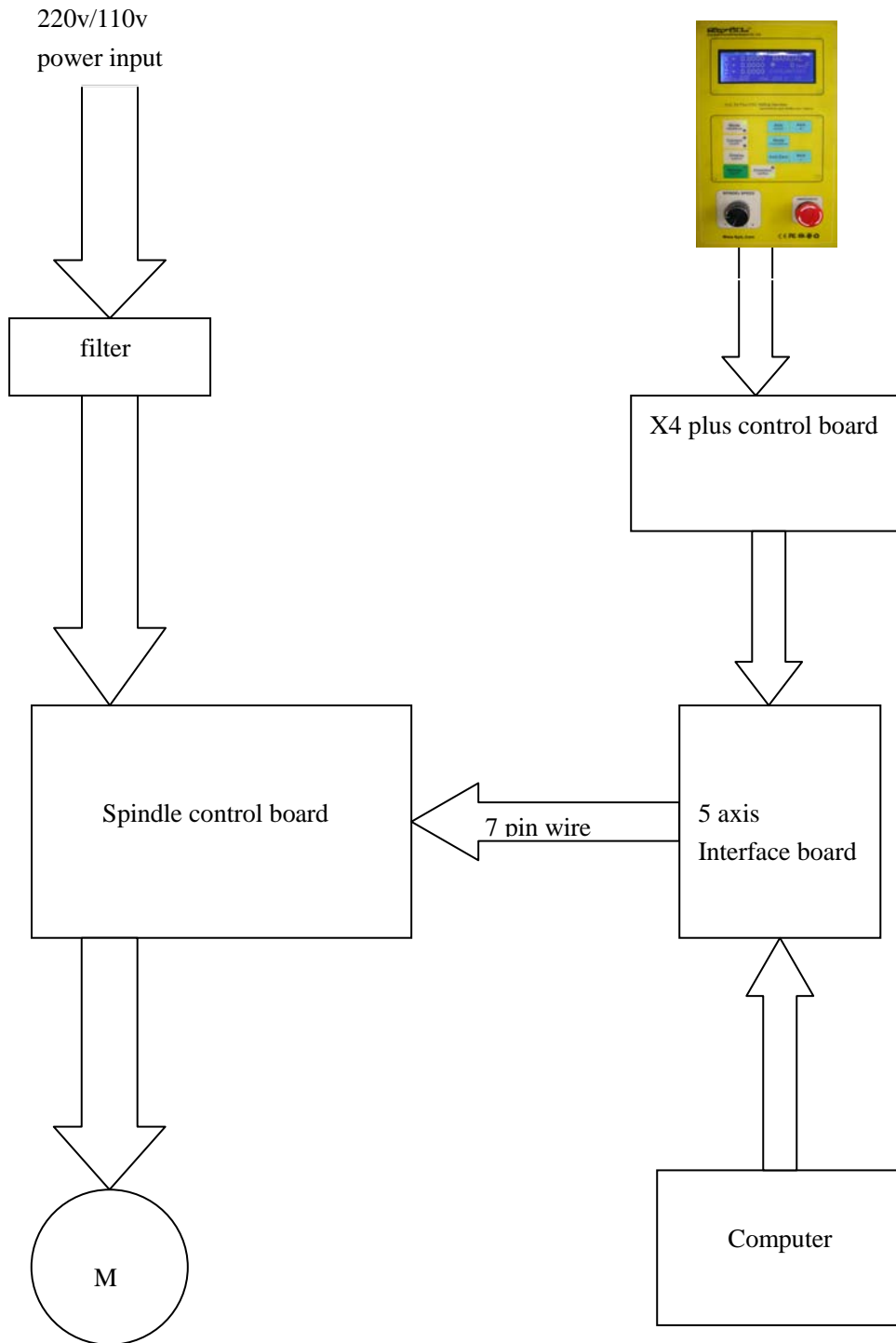

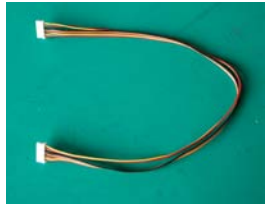
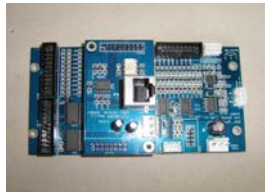



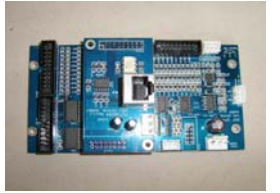



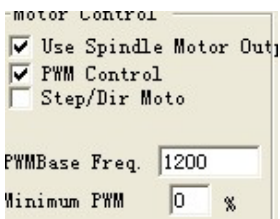

Figure 7-8

7.2.4.4 Problem resolution checklist for x4 plus

Problem	Action to identify cause of problem	How to solve	Remark
The spindle can't be controlled by computer.	1.check the parallel cable between computer and machine.	1. make sure the connection are good. If the cable have suspected problems, replace it.	
	2.check the parallel port	2. if the parallel port is broken replace it.	
	3.check mach3	3.if the software is broken by unknown problem, reinstall it	
	4.check the 7 pin wire	4.if the wire is broken, replace it	
	5.check the x4 plus control board	5.If the board have some problem, replace it	
	6.check the spindle control board	6.if the spindle control board is broken, replace it. To test check that the board is getting power.	
	7.check the spindle motor	7.if the motor is broken ,replace it	

	8.check the wire which connect to keyboard	8.If the switch is broken, replace it.	
The spindle can't be control by manual mode	1. check the wire which connect to keyboard	1.If the switch is broken, replace it.	
	2.check the x4 plus control board	2.If the board have some problem, replace it	
	3.check the Potentiometers	3.If the Potentiometers have some problem, replace it	
	4. check the 20 pin cable which connect to 5 axis interface board and parallel port	4.If the 20 pin cable is broken, replace it.	
The spindle does not achieve programmed RPM. For example, use "m3s1500", but the true RPM is only 1000	1. check set of pulleys in mach3	1.Make sure the pulley is 200 to 3600	
	2.check motor control in mach3	2.Make sure the PWMbase freq. is 1000 to 1500.	

7.2.4.5 Overview for x4 speed master

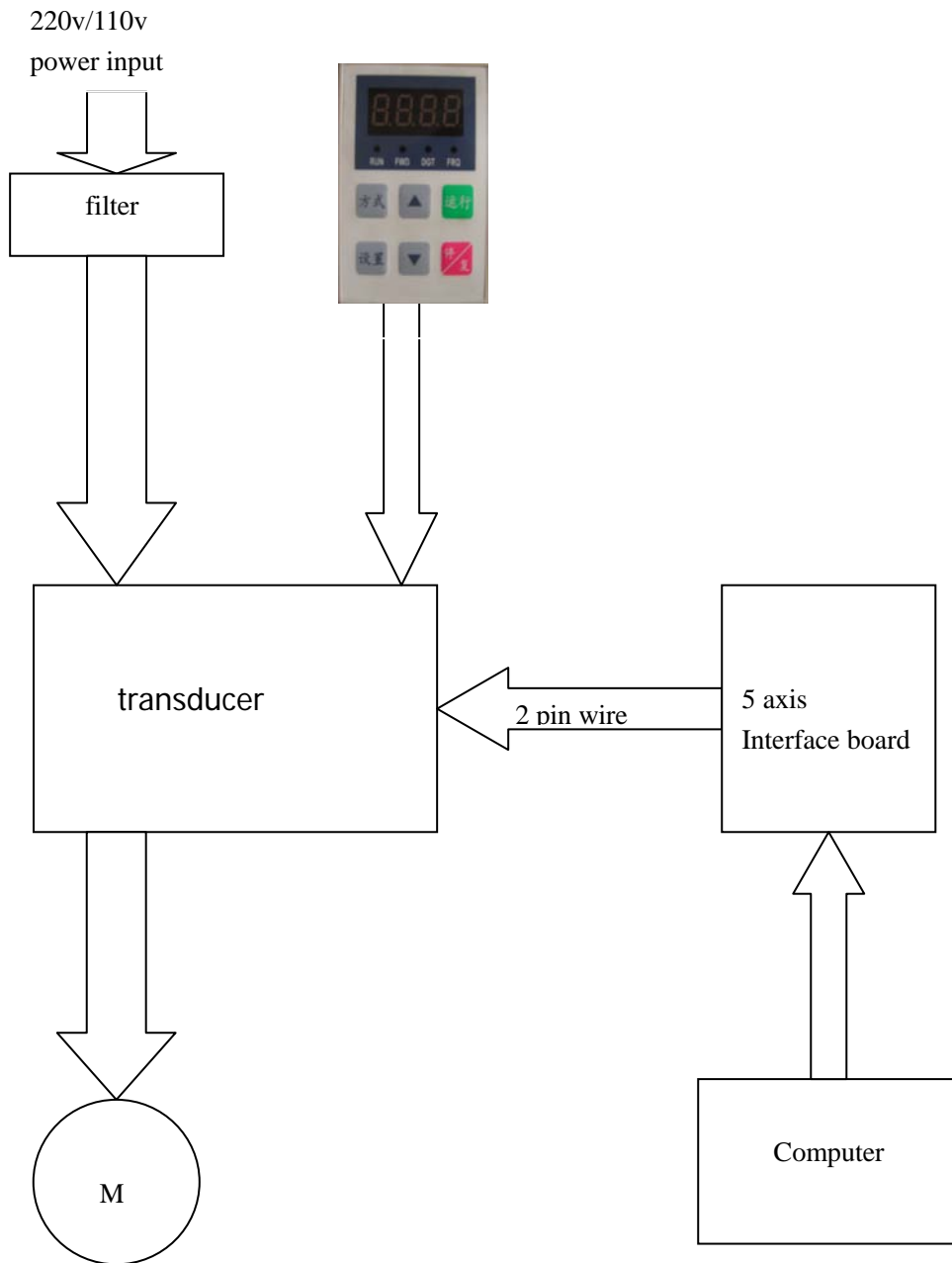







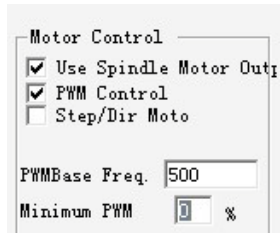

Figure 7-9

7.2.4.6 Problem resolution checklist for x4 speed master

Problem	Action to identify cause of problem	How to solve	Remark
The spindle can't be controlled by computer.	1.check the parallel cable between computer and machine.	1. make sure the connection are good. If the cable have suspected problems, replace it.	
	2.check the parallel port	2. if the parallel port is broken replace it.	
	3.check mach3	3.if the software is broken by unknown problem, reinstall it	
	4.check the transducer	6.if the transducer is broken, replace it. To test check that the board is getting power.	
	5.check the spindle motor	7.if the motor is broken ,replace it	
	6.check the signal transform board	8.If the board is broken, replace it.	
	7.check the interface board .	1.if the board is broken, replace it	

<p>The spindle does not achieve programmed RPM. For example, use "m3s15000", but the true RPM is only 10000</p>	<p>1. check set of pulleys in mach3</p>	<p>1. Make sure the pulley is 8000 to 24000</p>	 <p>The screenshot shows a 'Pulley Selection' dialog box with a 'Current Pulley' dropdown set to 'Pulley Number 3', 'Min Speed' set to 200, and 'Max Speed' set to 3600. There is a 'Reversed' checkbox which is unchecked and an 'OK' button.</p>
	<p>2. check motor control in mach3</p>	<p>2. Make sure the PWMbase freq. is 500.</p>	 <p>The screenshot shows a 'Motor Control' dialog box with three checked options: 'Use Spindle Motor Outp', 'PWM Control', and 'Step/Dir Moto'. Below these are input fields for 'PWMBase Freq.' set to 500 and 'Minimum PWM' set to 0%.</p>