

# HT23-400-8

## High Torque Stepper Motor

### 400 OzIn Hybrid Design

### 1.8 deg / 200 Steps Per Revolution

**THE GREEN MONSTER**



	Parallel	Series	UniPolar
Holding Torque (N.m +-10%)	2.8	2.8	2.0
Rated Current (Amps/phase)	4.2	2.1	3.0
Resistance (ohm/phase +-10%)	0.8	0.8	1.6
Inductance (mH/phase +-20%)	3.8	15.2	3.8
Rotor Inertia (g.cm <sup>2</sup> )	480		
Motor Weight (kg)	2.0		
Motor Length (mm)	112		
Number of Wires	8		

*UNIPOLAR RESP. ONE WINDING*

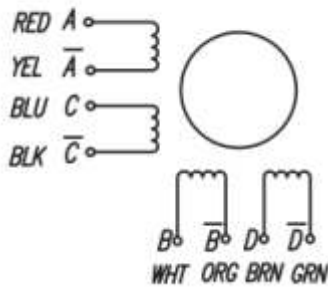

*BIPOLAR RESP. BIPOLAR SERIAL*

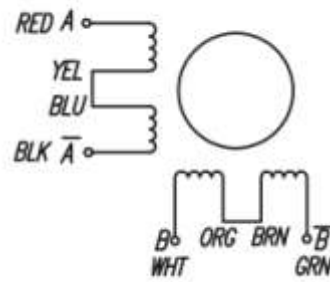

*BIPOLAR ONLY PARALLEL*

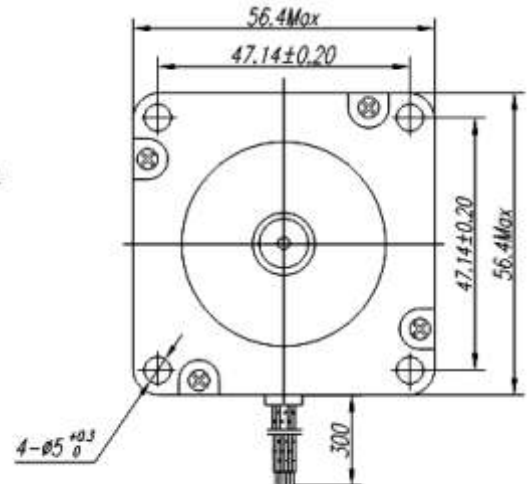
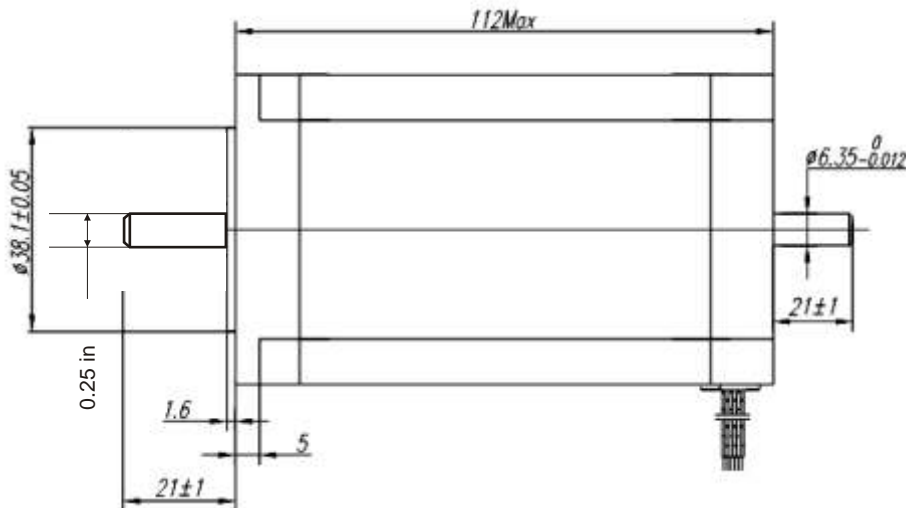
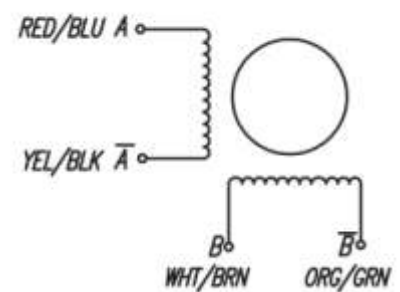

HT23-400-8 Torque Curve

